



Low voltage AC drives

# ABB machinery drives ACS355 0.5 to 30 hp/0.37 to 22 kW Catalog

Power and productivity  
for a better world™



# Selecting and ordering your drive

Type designation is a unique reference number that clearly identifies the drive by construction, power and voltage rating and selected options. Using the type designation you can specify your drives from the wide range of options available. Options are added to the type designation using the corresponding “plus” (+) code.

Build up your own ordering code using the type designation key below or contact your local ABB drives sales office and let them know what you want. Use page 3 as a reference section for more information.

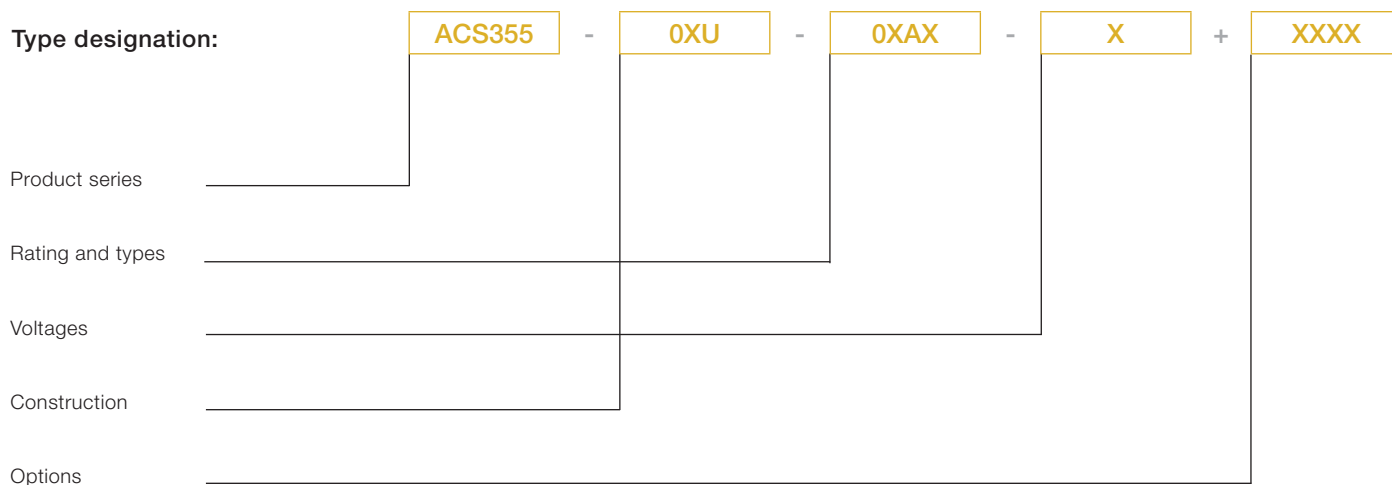

# Contents

## ABB machinery drives, ACS355

Introduction to ACS355	4
Main features	5
Typical applications	6
Ratings and types	7
Type designation	7
Voltages	7
Construction	7
Technical data	8
Dimensions and weights	9
Cabinet-mounted drives (IP20 UL Open)	9
Wall-mounted drives (NEMA 1/UL Type 1)	9
Wall-mounted drives (IP66/UL Type 4X)	9
Cooling	10
Circuit protection	11
Control connections	12
Connection examples	12
Control program example	13
Options	15
How to select options	15
User interfaces	16
Machine interfaces	17
Extension modules	17
Protection and installation	17
Sequence programming example: radio button	18
DriveBrowser	19
FlashDrop tool	20
Brake resistors	20
Input and output chokes	20
EMC filters	21
Low leakage current filters	21
Compact PLC and AC drive kit	22
Taking care of your drives, caring about your business	23

# Introduction to ACS355

ACS355

-

0XU

-

0XAX

-

X

+

XXXX

## ABB machinery drives

The ABB machinery drives are designed to be fast drives to install, parameter-set and commission. Thus saving hours of engineering work. They are highly compact and cost effective. Equipped with cutting-edge intelligence and safety capability the drives are designed specifically to meet the production and performance needs of system integrators, original equipment manufacturers (OEMs) and panel builders, as well as the requirements of end users in a broad range of applications.

In the ABB machinery drives portfolio, ACS355 represents the micro drive range; meeting requirements like compact size, being optimized for a lower power range, cost-effectiveness, and ease of use. By choosing an ABB machinery drive, machine builders not only get all the clever things inside the drive, but also everything outside it: the entire global ABB. This means a full range of products and services designed to support their business.

## Applications

ABB machinery drives are designed to meet the requirements of an extensive range of machinery applications. The drives are ideal for food and beverage, material handling, lifting, textile, printing, rubber and plastics, and woodworking applications.

## Highlights

- Exceptionally compact drives and uniform design
- Quick commissioning with application macros and panel assistants
- Safe torque off function (SIL3) as standard
- Sensorless vector control
- Built-in braking chopper

## High protection class drive

A range of ABB machinery drives with IP66 protection is designed for applications exposed to dust, moisture and cleaning chemicals such as screws, mixers, pumps, fans and conveyors. Typical industries that benefit from the drive include food and beverage, textile, ceramics, pulp and paper, water and wastewater, printing and rubber and plastics.

The heat sink's cooling fins are completely open from top to bottom, which allows easy washing to ensure no dirt adheres to the surfaces. Assistant control panel housed within a plastic window is designed to resist moist and dusty atmospheres. Furthermore, the cooling fan is located inside the drive, thereby eliminating the need for an external cooling fan and the subsequent maintenance of external moving parts.

The drive's hygienic design and use of materials meeting current hygiene standards, means that the drive traps no bacteria and can withstand frequent washing. The drive is certified by NSF.

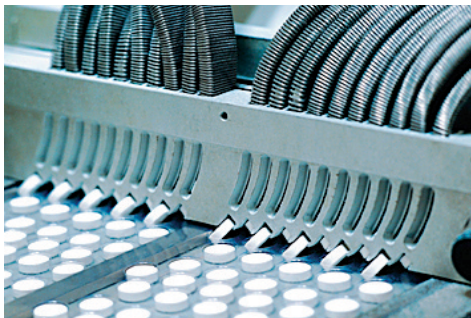

1. Textile  
2. Pharmaceutical

3. Food and beverage  
4. Material handling

5. Printing  
6. Lifting

# Main features

ACS355 - 0XU - 0XAX - X + B063

Feature	Advantage	Benefit
Worldwide availability and service	Drives are available worldwide and permanently stocked in four regions. Dedicated global service and support network that is one of the widest in the industry.	Fast and reliable delivery with dedicated support to any country in the world.
Broadest power range in its class from 0.5 to 30 hp	Drive series covers all the typical needs of machine builders with a single family of machinery drive.	Cost savings as machine builders need to choose only one drive series.
Exceptionally compact drives and uniform design	Drive has the highest power density in its class at 2.8 kW/dm <sup>3</sup> . All frame sizes share the same depth and height facilitating multiple drive solutions and cabinet installations.	Space savings in restricted spaces.
Safe torque off function (SIL3) as standard	Built-in and certified function that is used for prevention of an unexpected startup and other stopping related functions.	Reduces the need for external safety components Helps machine builders to fulfill the requirements of Machinery Directive 2006/42/EC.
Sequence programming	Simple drive control logic, with up to eight pre-set sequences of operations, is created in minutes with built-in sequence programming.	Reduces the need for external PLC components.
Application macros and control panel assistants	Pre-defined I/O configurations containing macros such as 3-wire, PID-control and motor potentiometer macro. Different assistants help set parameters for different functions such as drive startup, motor setup or PID control.	Enables quick commissioning of a drive.
FlashDrop tool	A pre-defined machine parameter set, from selection of up to 20, can be downloaded in seconds to a drive without powering the drive. The FlashDrop tool is easy to use and no specialized drives knowledge is required.	Fast, easy and reliable pre-configuration of drives for high-volume machine builders.
Speed compensated stop	A feature for applications that require precision stopping that is independent of variations in process speed.	Improved production flow and cost saving of a built-in feature.
Product variant for demanding environments with IP66/69K, UL Type 4X protection classes	No need to design special enclosure for application that requires a high ingress protection. NSF certified.	Time and cost savings.
Sensorless vector control for induction motors and permanent magnet motors	Accurate motor control without a feedback device. Patented smooth start for permanent magnet motors.	Cost saving of a reduced component. Increased energy efficiency by using PM motors.





# Typical applications

## Mixer

In mixing applications the drive provides a high starting torque. The silent operation mode adjusts the switching frequency of the drive to a higher level after the high-torque start, resulting in lower audible noise. The FlashDrop tool provides a quick and safe way to configure multiple drives for identical mixer applications.

## Conveyor

Production lines often have multiple stages, including conveyors, which need to be efficiently linked with each other to provide high production output. A drive provides smooth start and stop of the conveyor, thereby reducing mechanical stress and lowering maintenance costs.

## Packaging machine

Packaging machines often require a drive to provide a high degree of repeatability and accuracy during the packing operation. As such, the ACS355 is well suited for packaging duties and also provides good dynamic and static speed control accuracy. Sequence programming enables the drive to perform sequences of tasks, reducing the need for a PLC. Software features include timer, counter, brake control and jogging – all of which can be used in a packaging machine.

## Bottling line

When filling the bottles with liquid, bottling lines require a drive which offers high accuracy. An ACS355 is perfect for this purpose, with its good dynamic and static speed control.

When dealing with liquids, an ACS355 with a high protection class (IP66) would also be a good choice.

## Winder

ACS355 offers high static speed accuracy. When dealing with thin strings like in string winders, it is essential to control the winder speed accurately in order to prevent the strings from snapping. Surface winders, on the other hand, require high static speed accuracy to keep control of the material thickness or tension.



# Ratings and types

ACS355 - 0XU - 02A4 - 2 + B063

## Type designation

This is the unique reference number (shown above and in column 4, right) that clearly identifies your drive by power rating and frame size. Once the drive's type designation has been selected, the frame size (column 5) can be used to determine the drive dimensions, shown on the next page.

## Voltages

ACS355 is available in two voltage ranges:

2 = 200 to 240 V

4 = 380 to 480 V

Insert either "2" or "4", depending on your chosen voltage, into the type designation shown above.

## Construction

"01U" within the type designation (shown above) varies depending on the drive phase and EMC filtering. Choose below the one you need.

01 = 1-phase

03 = 3-phase

B063 = IP66/UL Type 4X enclosure

Ratings IP20/UL Open type/ NEMA 1 option			Type designation	Frame size
$P_N$ [hp]	$P_N$ [kW]	$I_{2N}$ [A]		
<b>1-phase AC supply, 200 to 240 V</b>				
0.5	0.37	2.4	ACS355-01U-02A4-2	R0
1.0	0.75	4.7	ACS355-01U-04A7-2	R1
1.5	1.1	6.7	ACS355-01U-06A7-2	R1
2.0	1.5	7.5	ACS355-01U-07A5-2	R2
3.0	2.2	9.8	ACS355-01U-09A8-2	R2
<b>3-phase AC supply, 200 to 240 V</b>				
0.5	0.37	2.4	ACS355-03U-02A4-2	R0
0.75	0.55	3.5	ACS355-03U-03A5-2	R0
1.0	0.75	4.7	ACS355-03U-04A7-2	R1
1.5	1.1	6.7	ACS355-03U-06A7-2	R1
2.0	1.5	7.5	ACS355-03U-07A5-2	R1
3.0	2.2	9.8	ACS355-03U-09A8-2	R2
5.0	4.0	17.6	ACS355-03U-17A6-2	R2
7.5	5.5	24.4	ACS355-03U-24A4-2	R3
10.0	7.5	31.0	ACS355-03U-31A0-2	R4
15.0	11.0	46.2	ACS355-03U-46A2-2	R4
<b>3-phase AC supply, 380 to 480 V</b>				
0.5	0.37	1.2	ACS355-03U-01A2-4	R0
0.75	0.55	1.9	ACS355-03U-01A9-4	R0
1.0	0.75	2.4	ACS355-03U-02A4-4	R1
1.5	1.1	3.3	ACS355-03U-03A3-4	R1
2.0	1.5	4.1	ACS355-03U-04A1-4	R1
3.0	2.2	5.6	ACS355-03U-05A6-4	R1
5.0	4.0	8.8	ACS355-03U-08A8-4	R1
7.5	5.5	12.5	ACS355-03U-12A5-4	R3
10.0	7.5	15.6	ACS355-03U-15A6-4	R3
15.0	11.0	23.1	ACS355-03U-23A1-4	R3
20.0	15.0	31.0	ACS355-03U-31A0-4	R4
25.0	18.5	38.0	ACS355-03U-38A0-4	R4
30.0	22.0	44.0	ACS355-03U-44A0-4	R4

Ratings IP66/UL Type 4U			Type designation	Frame size
$P_N$ [hp]	$P_N$ [kW]	$I_{2N}$ [A]		
<b>3-phase AC supply, 200 to 240 V</b>				
0.5	0.37	2.4	ACS355-03U-02A4-2 + B063	R1
0.75	0.55	3.5	ACS355-03U-03A5-2 + B063	R1
1.0	0.75	4.7	ACS355-03U-04A7-2 + B063	R1
1.5	1.1	6.7	ACS355-03U-06A7-2 + B063	R1
2.0	1.5	7.5	ACS355-03U-07A5-2 + B063	R1
3.0	2.2	9.8	ACS355-03U-09A8-2 + B063	R3
5.0	4.0	17.6	ACS355-03U-17A6-2 + B063	R3
<b>3-phase AC supply, 380 to 480 V</b>				
0.5	0.37	1.2	ACS355-03U-01A2-4 + B063	R1
0.75	0.55	1.9	ACS355-03U-01A9-4 + B063	R1
1.0	0.75	2.4	ACS355-03U-02A4-4 + B063	R1
1.5	1.1	3.3	ACS355-03U-03A3-4 + B063	R1
2.0	1.5	4.1	ACS355-03U-04A1-4 + B063	R1
3.0	2.2	5.6	ACS355-03U-05A6-4 + B063	R1
5.0	4.0	8.8	ACS355-03U-08A8-4 + B063	R1
7.5	5.5	12.5	ACS355-03U-12A5-4 + B063	R3
10.0	7.5	15.6	ACS355-03U-15A6-4 + B063	R3

$P_N$  for kW = Typical motor power in 400 V at normal use

$P_N$  for hp = Typical motor power in 460 V at normal use

$I_{2N}$  for A = Continuous rms current. 50% overload is allowed for one minute in ten minutes.

# Technical data

ACS355

-

OXU

-

OXAX

-

X

+

XXXX

## Mains connection

<b>Voltage and power range</b>	1-phase, 200 to 240 V $\pm$ 10% 0.5 to 3 hp (0.37 to 2.2 kW) 3-phase, 200 to 240 V $\pm$ 10% 0.5 to 15 hp (0.37 to 11 kW) 3-phase, 380 to 480 V $\pm$ 10% 0.5 to 30 hp (0.37 to 22 kW)
--------------------------------	-------------------------------------------------------------------------------------------------------------------------------------------------------------------------------------------------------

<b>Frequency</b>	48 to 63 Hz
------------------	-------------

## Common DC connection

<b>Voltage and power range</b>	230 V drives, 325 V $\pm$ 15% 400/480 V drives, 540 $\pm$ 15% (common DC manual) $P_{max} = P_n$ of the drive
--------------------------------	---------------------------------------------------------------------------------------------------------------------

## Motor connection

<b>Voltage</b>	3-phase, from 0 to $U_{SUPPLY}$
<b>Frequency</b>	0 to 599 Hz
<b>Continuous loading capability</b> (constant torque at a max. ambient temperature of 40 °C)	Rated output current $I_{2N}$
<b>Overload capacity</b> (at a max. ambient temperature of 40 °C)	1.5 $\times$ $I_{2N}$ for 1 minute every 10 minutes At start 1.8 $\times$ $I_{2N}$ for 2 s
<b>Switching frequency</b> Selectable	Default 4 kHz 4 to 16 kHz with 4 kHz steps
<b>Acceleration time</b>	0.1 to 1800 s
<b>Deceleration time</b>	0.1 to 1800 s
<b>Braking</b>	Built-in brake chopper as standard
<b>Speed control</b> Static accuracy Dynamic accuracy	20% of motor nominal slip < 1% s with 100% torque step
<b>Torque control</b> Torque step rise time Non-linearity	< 10 ms with nominal torque $\pm$ 5% with nominal torque

## Environmental limits

<b>Ambient temperature</b>	14 to 104 °F (-10 to 40 °C), no frost allowed 122 °F (50 °C) with 10% derating
<b>Altitude</b>	Rated current available at 0 to 1000 m. In altitudes from 1000 to 2000 m (3300 to 13,200 ft) above sea level, the derating is 1% for every 100 m (330 ft). If the installation site is higher than 2000 m (6600 ft) above sea level, please contact your local ABB distributor or office for further information.
<b>Relative humidity</b>	Lower than 95% (without condensation)
<b>Degree of protection</b>	IP20/optional NEMA 1/UL type 1 enclosure IP66/UL Type 4X as an option up to 7.5 kW, IP69K available for IP66 variant with compatible cable glands
<b>Enclosure colour</b>	NCS 1502-Y, RAL 9002, PMS 420 C
<b>Contamination levels</b>	IEC721-3-3 No conductive dust allowed
Transportation	Class 1C2 (chemical gases)
Storage	Class 1S2 (solid particles)
Operation	Class 2C2 (chemical gases) Class 2S2 (solid particles) Class 3C2 (chemical gases) Class 3S2 (solid particles)

## Product compliance

Low Voltage Directive 2006/95/EC  
Machinery Directive 2006/42/EC  
EMC Directive 2004/108/EC  
Quality assurance system ISO 9001  
Environmental system ISO 14001  
UL, cUL, CE, C-Tick and GOST R approvals  
RoHS compliant

## Programmable control connections

<b>Two analog inputs</b> Voltage signal Unipolar Bipolar Current signal Unipolar Bipolar Potentiometer reference value Resolution Accuracy	0 (2) to 10 V, $R_{in} > 312$ k $\Omega$ -10 to 10 V, $R_{in} > 312$ k $\Omega$ 0 (4) to 20 mA, $R_{in} = 100$ $\Omega$ -20 to 20 mA, $R_{in} = 100$ $\Omega$ 10 V $\pm$ 1% max. 10 mA, $R < 10$ k $\Omega$ 0.1% $\pm$ 2%
<b>One analog output</b>	0 (4) to 20 mA, load < 500 $\Omega$
<b>Auxiliary voltage</b>	24 V DC $\pm$ 10%, max. 200 mA
<b>Five digital inputs</b> Input impedance	12 to 24 V, PNP and NPN, programmable DI5 0 to 16 kHz pulse train 2.4 k $\Omega$
<b>One relay output</b> Type Maximum switching voltage Maximum switching current Maximum continuous current	NO + NC 250 V AC/30 V DC 0.5 A/30 V DC; 5 A/230 V AC 2 A rms
<b>One digital output</b> Type Maximum switching voltage Maximum switching current Frequency Resolution Accuracy	Transistor output 30 V DC 100 mA/30 V DC, short circuit protected 10 Hz to 16 kHz 1 Hz 0.2%

## Serial and Ethernet communication

<b>Fieldbuses</b> Refresh rate	Plug-in type < 10 ms (between drive and fieldbus module)
<b>DeviceNet™</b>	5-pin screw type connector, up to 500 kbit/s baud rate
<b>PROFIBUS DP</b>	9-pin D-connector, up to 12 Mbit/s baud rate
<b>CANopen®</b>	9-pin D-connector, up to 1 Mbit/s
<b>Modbus RTU</b>	4-pin screw type connector, up to 115 kbit/s baud rate
<b>EtherNet/IP™, Modbus TCP, PROFINET IO</b>	RJ-45 connector, 10/100 Mbit/s baud rate
<b>LonWorks®</b>	3-pin screw type connector, up to 78 kbit/s baud rate
<b>EtherCAT®</b>	2 pcs RJ-45 connectors, 100 Mbit/s baud rate

## Chokes

<b>AC input chokes</b>	External option. For reducing THD in partial loads and to comply with EN/IEC 61000-3-12.
<b>AC output chokes</b>	External option. To achieve longer motor cables.

## Mains connection, high protection class drive

<b>Voltage and power range</b>	3-phase, 200 to 240 V $\pm$ 10% 0.5 to 5 hp (0.37 to 4 kW) 3-phase, 380 to 480 V $\pm$ 10% 0.5 to 10 hp (0.37 to 7.5 kW)
--------------------------------	-----------------------------------------------------------------------------------------------------------------------------------

## Environmental limits, high protection class drive

<b>Ambient temperature</b>	14 to 104 °F (-10 to 40 °C), no frost allowed
<b>Degree of protection</b>	IP66/UL Type 4X, indoor use only IP69K with compatible cable glands

## Product compliance, high protection class drive

Low Voltage Directive 2006/95/EC  
Machinery Directive 2006/42/EC  
EMC Directive 2004/108/EC  
Quality assurance system ISO 9001  
Environmental system ISO 14001  
UL, cUL, CE, C-Tick and GOST R approvals  
RoHS compliant  
NSF Certified  
DIN40050-9 (IP69K)



# Dimensions and weights

ACS355 - 0XU - 0XAX - X + XXXX

## Cabinet-mounted drives (IP20 UL Open)

Frame size	IP20 UL Open						
	H1 in	H2 in	H3 in	W in	D1 in	D2 in	Weight lb
R0	6.7	8.0	9.4	2.8	6.3	7.4	2.6
R1	6.7	8.0	9.4	2.8	6.3	7.4	2.6
R2	6.7	8.0	9.4	4.1	6.5	7.5	3.3
R3	6.7	8.0	9.3	6.7	6.7	7.7	5.5
R4	7.1	8.0	9.6	10.2	6.7	7.7	9.7

H1 = Height without fastenings and clamping plate  
 H2 = Height with fastenings but without clamping plate  
 H3 = Height with fastenings and clamping plate  
 W = Width  
 D1 = Standard depth  
 D2 = Depth with MREL, MPOW or MTAC option

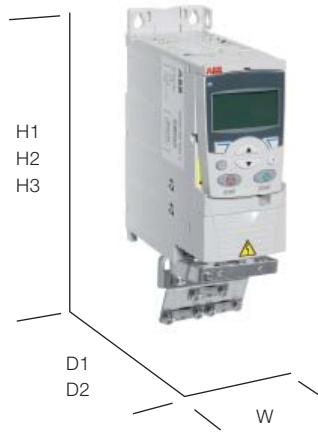

## Wall-mounted drives (NEMA 1/UL Type 1)

Frame size	NEMA 1/UL Type 1					
	H4 in	H5 in	W in	D1 in	D2 in	Weight lb
R0	10.1	11.0	2.8	6.7	7.4	3.5
R1	10.1	11.0	2.8	6.7	7.4	3.5
R2	10.1	11.1	4.1	6.7	7.5	4.2
R3	10.2	11.8	6.7	7.0	7.7	6.8
R4	10.6	12.6	10.2	7.0	7.7	11.0

H4 = Height with fastenings and NEMA 1 connection box  
 H5 = Height with fastenings, NEMA 1 connection box and hood  
 W = Width  
 D1 = Standard depth  
 D2 = Depth with MREL, MPOW or MTAC option

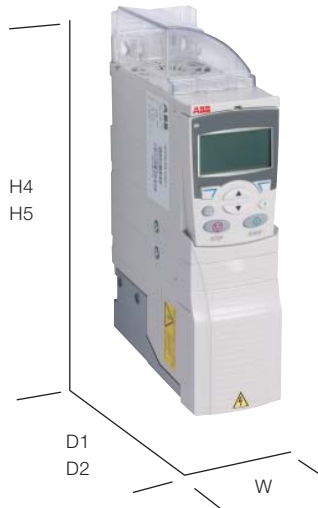

## Wall-mounted drives (IP66/UL Type 4X)

Frame size	IP66/UL Type 4X			
	H in	W in	D1 in	Weight lb
R1	12.0	7.7	11.1	16.9
R3	17.2	9.7	10.9	28.6

H = Height  
 W = Width  
 D1 = Standard depth



# Cooling

## Cooling

ACS355 is fitted with cooling fans as standard. The cooling air must be free from corrosive substances and must not be above the maximum ambient temperature of 40 °C (50 °C with

derating). Heat dissipation from IP66/UL Type 4X drive equals to the IP20 UL Open values. For more specific limits see the Technical specification - Environmental limits in this catalog.

## Cooling air flow

Type designation	Frame size	Heat dissipation		Air flow	
		[W]	BTU/hr <sup>1)</sup>	ft <sup>3</sup> /min	m <sup>3</sup> /h
<b>1-phase AC supply, 200 to 240 V</b>					
ACS355-01U-02A4-2	R0	48	163	- <sup>2)</sup>	- <sup>2)</sup>
ACS355-01U-04A7-2	R1	72	247	14	24
ACS355-01U-06A7-2	R1	97	333	14	24
ACS355-01U-07A5-2	R2	101	343	12	21
ACS355-01U-09A8-2	R2	124	422	12	21
<b>3-phase AC supply, 200 to 240 V</b>					
ACS355-03U-02A4-2	R0	42	142	- <sup>2)</sup>	- <sup>2)</sup>
ACS355-03U-03A5-2	R0	54	183	- <sup>2)</sup>	- <sup>2)</sup>
ACS355-03U-04A7-2	R1	64	220	14	24
ACS355-03U-06A7-2	R1	86	295	14	24
ACS355-03U-07A5-2	R1	88	302	12	21
ACS355-03U-09A8-2	R2	111	377	12	21
ACS355-03U-17A6-2	R2	180	613	31	52
ACS355-03U-24A4-2	R3	285	975	42	71
ACS355-03U-31A0-2	R4	328	1119	57	96
ACS355-03U-46A2-2	R4	488	1666	57	96
<b>3-phase AC supply, 380 to 480 V</b>					
ACS355-03U-01A2-4	R0	35	121	- <sup>2)</sup>	- <sup>2)</sup>
ACS355-03U-01A9-4	R0	40	138	- <sup>2)</sup>	- <sup>2)</sup>
ACS355-03U-02A4-4	R1	50	170	8	13
ACS355-03U-03A3-4	R1	60	204	8	13
ACS355-03U-04A1-4	R1	69	235	8	13
ACS355-03U-05A6-4	R1	90	306	11	19
ACS355-03U-08A8-4	R1	127	433	14	24
ACS355-03U-12A5-4	R3	161	551	31	52
ACS355-03U-15A6-4	R3	204	697	31	52
ACS355-03U-23A1-4	R3	301	1029	42	71
ACS355-03U-31A0-4	R4	408	1393	57	96
ACS355-03U-38A0-4	R4	498	1700	57	96
ACS355-03U-44A0-4	R4	588	2007	57	96

X within the type designation stands for E or U.

<sup>1)</sup> BTU/hr = British Thermal Unit per hour. BTU/hr is approximately 0.293 Watts.

<sup>2)</sup> Frame size R0 with free convection cooling.

## Free space requirements

Enclosure type	Space above in	Space below in	Space on left/right in
All frame sizes	3.0	3.0	0.0
IP66 enclosure	3.0	3.0	0.8

# Circuit protection

## Circuit protection

Standard fuses and manual motor protectors can be used with ACS355 drive. See table below for selecting the correct fuse for correct drive type.



### Selection table

Type designation	Frame size	IEC fuses		UL fuses	Manual motor protector	
		[A]	Fuse type <sup>1)</sup>	UL Class T or CC (600 V) [A]	MMP type code <sup>3) 4)</sup>	Trip current setting [A]
<b>1-phase AC supply, 200 to 240 V</b>						
ACS355-01U-02A4-2	R0	10	gG	10	MS132-6.3 & S1-M3-25 <sup>5)</sup>	6.1
ACS355-01U-04A7-2	R1	16	gG	20	MS451-16E	11.0
ACS355-01U-06A7-2	R1	16/20 <sup>2)</sup>	gG	25	MS451-20E	16.0
ACS355-01U-07A5-2	R2	20/25 <sup>2)</sup>	gG	30	MS451-20E	17.0
ACS355-01U-09A8-2	R2	25/35 <sup>2)</sup>	gG	35	MS451-25E	21.0
<b>3-phase AC supply, 200 to 240 V</b>						
ACS355-03U-02A4-2	R0	10	gG	10	MS132-6.3 & S1-M3-25 <sup>5)</sup>	4.3
ACS355-03U-03A5-2	R0	10	gG	10	MS132-6.3 & S1-M3-25 <sup>5)</sup>	6.1
ACS355-03U-04A7-2	R1	10	gG	15	MS132-10 & S1-M3-25 <sup>5)</sup>	7.6
ACS355-03U-06A7-2	R1	16	gG	15	MS451-16E	12.0
ACS355-03U-07A5-2	R1	16	gG	15	MS451-16E	12.0
ACS355-03U-09A8-2	R2	16	gG	20	MS451-16E	14.0
ACS355-03U-17A6-2	R2	25	gG	35	MS451-32E	25.0
ACS355-03U-24A4-2	R3	63	gG	60	MS451-45E	41.0
ACS355-03U-31A0-2	R4	80	gG	80	MS495-63E	50.0
ACS355-03U-46A2-2	R4	100	gG	100	MS495-75E	69.0
<b>3-phase AC supply, 380 to 415 V<sup>6)</sup></b>						
ACS355-03U-01A2-4	R0	10	gG	10	MS132-2.5 & S1-M3-25 <sup>5)</sup>	2.2
ACS355-03U-01A9-4	R0	10	gG	10	MS132-4.0 & S1-M3-25 <sup>5)</sup>	3.6
ACS355-03U-02A4-4	R1	10	gG	10	MS132-6.3 & S1-M3-25 <sup>5)</sup>	4.1
ACS355-03U-03A3-4	R1	10	gG	10	MS132-6.3 & S1-M3-25 <sup>5)</sup>	6.0
ACS355-03U-04A1-4	R1	16	gG	15	MS132-10 & S1-M3-25 <sup>5)</sup>	6.9
ACS355-03U-05A6-4	R1	16	gG	15	MS132-10 & S1-M3-25 <sup>5)</sup>	9.6
ACS355-03U-08A8-4	R1	20	gG	25	MS451-16E	14.0
ACS355-03U-12A5-4	R3	25	gG	30	MS451-20E	19.0
ACS355-03U-15A6-4	R3	35	gG	35	MS451-25E	22.0
ACS355-03U-23A1-4	R3	50	gG	50	MS451-32E	31.0
ACS355-03U-31A0-4	R4	80	gG	80	MS495-63E	52.0
ACS355-03U-38A0-4	R4	100	gG	100	MS495-63E	61.0
ACS355-03U-44A0-4	R4	100	gG	100	MS495-75E	67.0
<b>3-phase AC supply, 440 to 480 V<sup>6)</sup></b>						
ACS355-03U-01A2-4	R0	10	gG	10	MS132-2.5 & S1-M3-25 <sup>5)</sup>	1.8
ACS355-03U-01A9-4	R0	10	gG	10	MS132-4.0 & S1-M3-25 <sup>5)</sup>	3.0
ACS355-03U-02A4-4	R1	10	gG	10	MS132-4.0 & S1-M3-25 <sup>5)</sup>	3.4
ACS355-03U-03A3-4	R1	10	gG	10	MS132-6.3 & S1-M3-25 <sup>5)</sup>	5.0
ACS355-03U-04A1-4	R1	16	gG	15	MS132-6.3 & S1-M3-25 <sup>5)</sup>	5.8
ACS355-03U-05A6-4	R1	16	gG	15	MS132-10 & S1-M3-25 <sup>5)</sup>	8.0
ACS355-03U-08A8-4	R1	20	gG	25	MS451-16E	11.0
ACS355-03U-12A5-4	R3	25	gG	30	MS451-20E	16.0
ACS355-03U-15A6-4	R3	35	gG	35	MS451-20E	18.0
ACS355-03U-23A1-4	R3	50	gG	50	MS451-32E	26.0
ACS355-03U-31A0-4	R4	80	gG	80	MS451-45E	43.0
ACS355-03U-38A0-4	R4	100	gG	100	MS495-63E	51.0
ACS355-03U-44A0-4	R4	100	gG	100	MS495-63E	56.0

Other fuse types can be used if they meet the ratings and the melting curve of the fuse does not exceed the melting curve of the fuse mentioned in this table.

<sup>1)</sup> According to IEC-60269 standard.

<sup>2)</sup> If 50% overload capacity is needed, use the bigger fuse alternative.

<sup>3)</sup> All manual motor protectors listed are Type E self-protected up to 65 kA.

<sup>4)</sup> Manual motor protectors may require adjusting the trip limit from the factory setting at or above the drive input Amps to avoid nuisance tripping. If the manual motor protector is set to the maximum current trip level and nuisance tripping is occurring, then select the next size MMP. (MS132-10 is the highest size in MS132 frame size to meet Type E at 65 kA; the next size up is the MS451-16E).

<sup>5)</sup> S1-M3-25 line side feeder terminal is needed with manual motor protector to meet Type E self protection class according to UL and cUL requirements.

<sup>6)</sup> 480Y/277V only.

# Control connections

ACS355 - 0XU - 0XAX - X + XXXX

## Application macros

Application macros are preprogrammed parameter sets. While starting up the drive, the user typically selects one of the macros that is best suited for the application. The diagram below gives an overview of ACS355 control connections and shows the default I/O connections for the ABB standard macro.

ABB machinery drives have eight application macros:

- ABB standard macro
- Torque control macro
- 3-wire macro

- Alternate macro
- AC500 Modbus macro
- Motor potentiometer macro
- Hand/auto macro
- PID control macro

In addition to the standard macros the user can create three user macros. The user macro allows the user to save the parameter settings for later use.

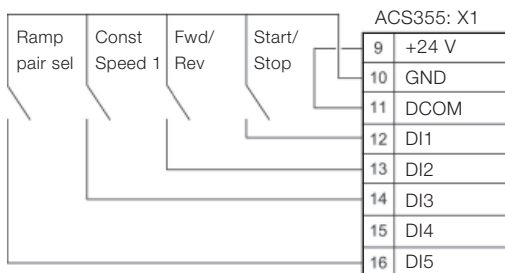
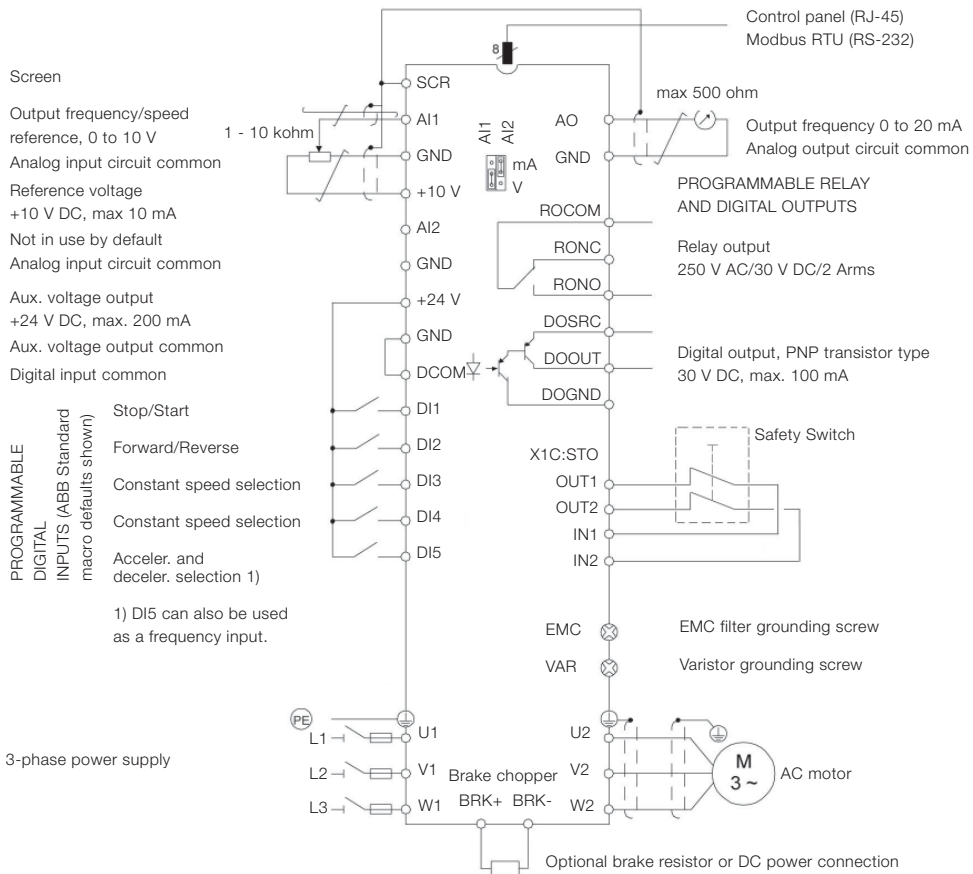

Sinking DI configuration (NPN connected).

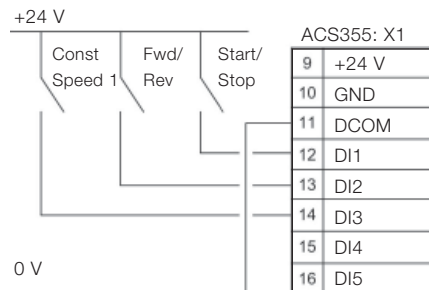

Sourcing DI configuration (PNP connected) with external power supply.

# Control program example

ACS355 - 0XU - 0XAX - X + XXXX

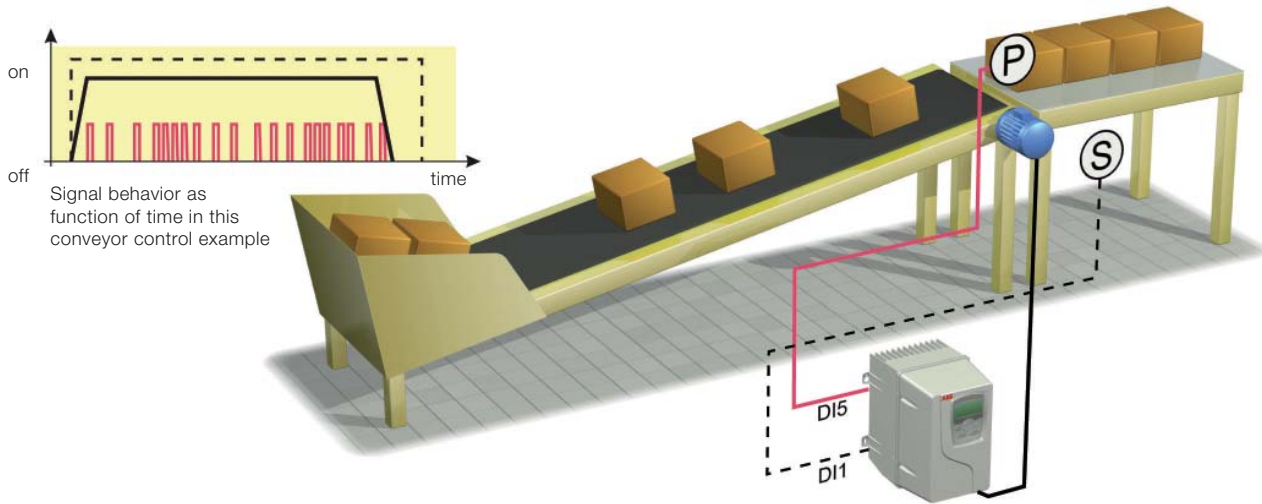

The ACS355 drives have many solutions for common challenges. The following example explains how the COUNTER STOP function operates within a conveyor unloading routine. The function stops the conveyor after a predefined number of boxes have passed the sensor.

The operator starts the conveyor by activating the drive using switch, S. The switch is connected to digital input 1 (DI1). The drive accelerates to a constant speed of 30 Hz with a 1 second ramp time.

Meanwhile a sensor, or proximity switch, P, is connected to digital input 5 (DI5). This sensor generates one pulse, every time a box on the conveyor passes by. When the required number of boxes – in this case 20 – have passed the sensor, the drive stops with a 1 second ramp time.

## Parameter settings

### Startup data

The correct motor parameters are set within parameter group 99. However, if the current and voltage settings of the motor and drive match, this is not necessary. The ACS355 also features vector control, which can be used by setting the relevant parameters and undertaking an ID run.

### Start/Stop/Direction logic

Parameter 1001 EXT1 COMMANDS is set to COUNTER STOP [24]. Under certain conditions the counter output will modify the start/stop signal for stopping.

### Constant speed selection

Parameter 1201 CONST SPEED SEL is set to DI1 [1]. Parameter 1202 CONST SPEED 1 acts as a speed reference source when digital input 1 is active.

Parameter 1202 CONST SPEED 1 is set to 30 Hz.

### Start/Stop functions

Parameter 2101 START FUNCTION is set to AUTO [1], which is also the default value. If high torque is required for the conveyor to start, settings DC MAGN [2] can be used.

Parameter 2102 STOP FUNCTION is set to RAMP [2]. Thus the drive ramps down to 0 at a stop command.

### Counter parametrization

Parameter 1904 COUNTER ENABLE is set to DI1 [1]. Counter is enabled now by digital input 1. When digital input 1 is low, the counter is not counting.

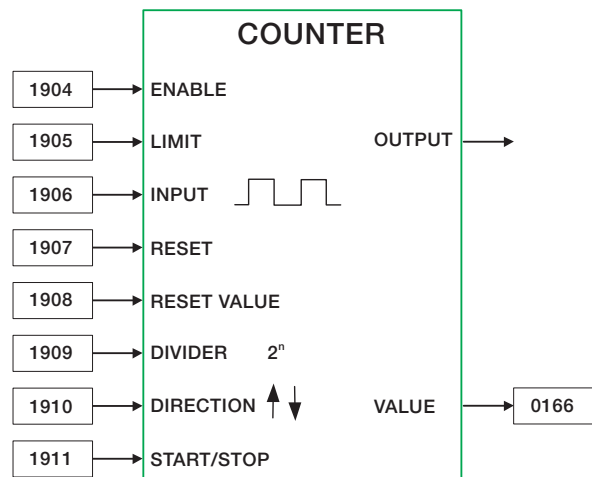



# Control program example



Parameter 1905 COUNTER LIMIT is set to 20. In this example the loading station can only hold 20 boxes.

Parameter 1906 COUNTER INPUT is set to PLS IN (DI5) [1] which is also the default value. Pulse counter P is wired to digital input (DI5). This digital input can also handle high frequency pulses up to 10 kHz. If the counter signal edges are swinging, this parameter can be set to FILTERED DI5 [4].

Parameter 1907 COUNTER RESET is set to DI1 (INV) [-1]. When digital input 1 is low, the counter is reset to a value determined by parameter 1908 COUNTER RES VAL.

Parameter 1908 COUNTER RES VAL is set to zero, which is also the default value. The counter, in this example, runs from 0 to 20.

Parameter 1909 COUNT DIVIDER is set to zero, which is also the default value. This value is used to divide high frequency pulse numbers to lower values. For example a 1024 pulse incremental encoder would give 1024 pulses in one revolution. When using count divider 10 (2 to the power of 10) the counter would count up by 1 after 1024 pulses.

Parameter 1910 COUNT DIRECTION is set to UP [0], which is also the default value.

Parameter 1911 CNTR S/S COMMAND is set to DI1 [1]. Digital input 1 acts as the drive start command. Due to the setting of parameter 1001 EXT1 COMMANDS, the drive stops when the counter limit has been reached or digital input 1 goes low.

The counter's actual value can now be seen from signal 0166.

## Acceleration and deceleration settings

Parameter 2201 ACC/DEC 1/2 SEL is set to NOT SEL [0]. Only one ramp is used in this application, thereby ramp changing is disabled.

Parameter 2202 ACCELER TIME 1 is set to 1s.

Parameter 2203 DECELER TIME 2 is set to 1s.

## ACS355 control program functions

ACS355 control program provides the following functions:

- Counter start and stop
- Timer start and stop
- Speed compensated stop
- 3 independent supervision functions
- Automatic restart function
- 2 sets of ramping times
- S-curve for ramping
- 7 constant speeds
- 3 critical speed ranges
- Maintenance triggers
- Timed functions
- Configurable fault/protection functions
- 2 process PID functions
- PID sleep function
- PID trim function
- Mechanical brake control
- 8 state sequence programming
- 2 sets of user parameter sets
- Safe torque off
- Parameter lock

## The ACS355 features the following motor control functions:

- Current, torque, speed and frequency limits
- Under- and overvoltage controllers
- Starting to the rotating machine
- Linear, squared and user defined U/f curves for scalar control
- IR compensation for scalar control
- Flux optimization for energy saving
- Flux braking for improved ramping down
- Drive temperature controlled switching frequency control
- Motor noise smoothing
- Sensorless vector control for induction motors
- Sensorless vector control for permanent magnet motors
- Smooth starting function for permanent magnet motors
- PID speed controller in vector controlled mode
- Acceleration compensation
- Speed controller auto tune
- Standalone and rotating motor identification runs
- Optional speed feed back for closed loop vector control

# Options

ACS355 - 0XU - 0XAX - X + XXXX

## How to select options

The options shown in the table are available within the ACS355 range. The ordering code, which is shown in the second column, replaces the XXXX in the type designation above. You can order as many options as required, simply by extending the code as necessary.

Options	Ordering code	Description	Model	Availability	
				IP20 drive	IP66 drive
<b>Protection class</b>	ʹ	NEMA 1/UL type 1 (R0, R1, R2)	MUL1-R1	■	-
	ʹ	NEMA 1/UL type 1 (R3)	MUL1-R3	■	-
	ʹ	NEMA 1/UL type 1 (R4)	MUL1-R4	■	-
	B063	IP66/UL type 4X enclosure		-	■
<b>Control panel</b> (choose one option only)	J400	Assistant control panel	ACS-CP-A	□	●
	J404	Basic control panel	ACS-CP-C	□	-
<b>Panel mounting kit</b>	ʹ	Panel mounting kit	ACS/H-CP-EXT	□	-
	ʹ	Panel holder mounting kit	OPMP-01	□	-
<b>Potentiometer</b>	J402	Potentiometer	MPOT-01	□	-
<b>Fieldbus</b> (choose one option only)	K451	DeviceNet™	FDNA-01	□	□
	K454	PROFIBUS DP	FPBA-01	□	□
	K457	CANopen®	FCAN-01	□	□
	K458	Modbus RTU	FMBA-01	□	□
	K466	EtherNet/IP™, Modbus TCP, PROFINET IO	FENA-01	□	□
	K452	LonWorks®	FLON-01	□	□
	K469	EtherCAT®	FECA-01	□	□
<b>Extension modules</b> (choose one option only)	ʹ	RS-485/Modbus	FRSA-00	□	□
		Speed encoder module	MTAC-01	□	-
		Relay output module	MREL-01	□	-
	Auxiliary power extension module	MPOW-01	□	-	
<b>Remote monitoring</b>	ʹ	Ethernet adapter	SREA-01	□	□
<b>Connection options</b>	H376	Cable gland kit (IP66/UL Type 4X)		-	□
	F278	Input switch kit		-	□
<b>Pressure compensation</b>	C169	Pressure compensation valve		-	□
<b>Tools</b>	ʹ	FlashDrop tool	MFDT-01	□	□
	ʹ	DriveWindow Light	DriveWindow Light	□	□
<b>External options</b>	ʹ	Input chokes		□	□ <sup>1)</sup>
	ʹ	EMC filters		□	□ <sup>1)</sup>
	ʹ	Braking resistors		□	□ <sup>1)</sup>
	ʹ	Output chokes		□	□ <sup>1)</sup>

● = Standard

■ = Product variant

□ = Option, external

- = Not available

ʹ = To be ordered as a separate item

<sup>1)</sup> External options not available in IP66/UL Type 4X protection class

# Options Interface



## User interfaces

### Panel cover

The purpose of the panel cover is to protect the drive's connection surfaces. The ACS355 drive is delivered with a panel cover as standard. In addition there are two alternative control panels available as options.

### Basic control panel

The basic control panel features a single line numeric display. The panel can be used to control the drive, set the parameter values or copy them from one drive to another.

### Assistant control panel

The assistant control panel features a multilingual alphanumeric display for easy drive programming. The control panel has various assistants and an built-in help function to guide the user. It includes a real time clock, which can be used during fault logging and in controlling the drive, such as start/stop. The control panel can be used for copying parameters for back up or for downloading to another drive. A large graphical display and soft keys make it extremely easy to navigate. The drive with IP66 enclosure has the assistant control panel as standard.



Panel cover (included as standard)

### Potentiometer

Potentiometer MPOT-01 with two switches: start/stop and forward/reverse. Polarity is selected with DIP switches. No external power source is needed for the potentiometer.

### Panel mounting kits

To attach the control panel to the outside of a larger enclosure, two panel mounting kits are available. A simple and cost-efficient installation is possible with the ACS/H-CP-EXT kit, while the OPMP-01 kit provides a more user-friendly solution, including a panel platform that enables the panel to be removed in the same way as a drive-mounted panel. The panel mounting kits include all hardware required eg, 3 m extension cables and installation instructions.



Basic control panel



Assistant control panel



Potentiometer



Panel holder mounting kit OPMP-01

# Options Interface



Fieldbus module

NEMA 1/UL type 1 kit

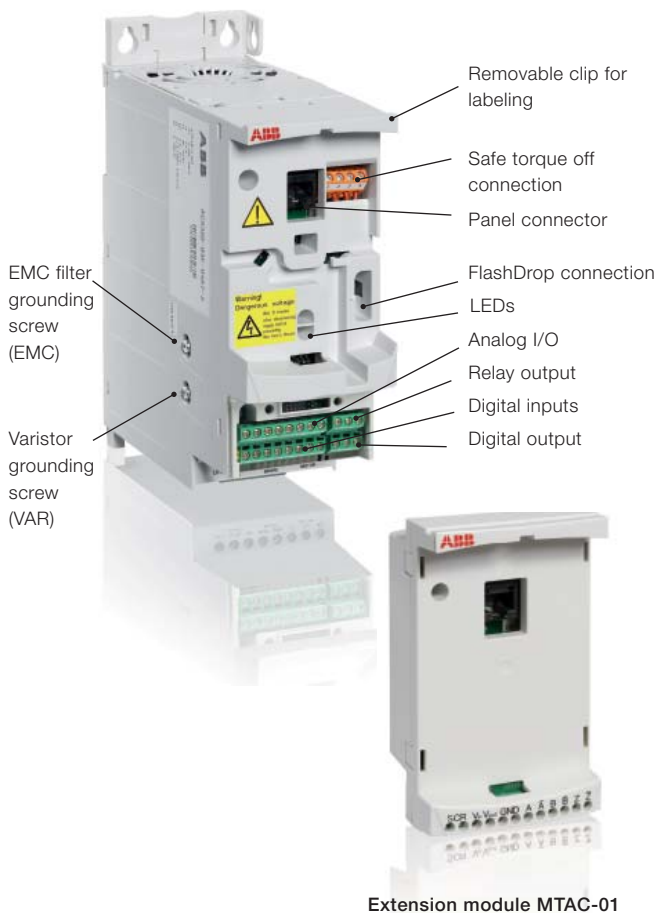

Extension module MTAC-01

## Machine interfaces

The plug-in fieldbus modules bring connectivity to major automation systems. A single twisted pair cable avoids large amounts of conventional cabling, thereby reducing costs and increasing system reliability.

ACS355 supports the following fieldbus options:

- PROFIBUS DP
- CANopen®
- DeviceNet™
- Modbus RTU
- EtherNet/IP™, Modbus TCP, PROFINET IO
- LonWorks®
- EtherCAT®

## Extension modules

### MREL-01

ACS355 has one relay output as standard. The optional MREL-01 module offers three additional relay outputs, which can be configured for different functions with parameters.

### MTAC-01

The optional MTAC-01 module offers pulse encoder interface for speed measurement.

### MPOW-01

The optional auxiliary power module MPOW-01 enables the drive control circuitry to be operated under all conditions.

## Protection and installation

### NEMA 1/UL Type 1 kit

The NEMA 1/UL Type 1 kit includes a connection box for finger protection, conduit tube installation, and a hood for protection against dirt and dust.

### Terminal cover

The terminal cover is for protection of the I/O connections.

### Clamping plates

The clamping plates are used for protection against electrical disturbances. The clamping plates with clamps are included in the drive package as standard.

# Options

## Software tools

A separate order line and type code is required for any of these software tool options.

### DriveWindow Light

DriveWindow Light is an easy-to-use commissioning and maintenance tool for ACS355 drives. It can be used in an offline mode, which enables parameter setting at the office even before going to the actual site. The parameter browser enables viewing, editing and saving of parameters. The parameter comparison feature makes it possible to compare parameter values between the drive and saved parameter files. With the parameter subset you can create your own parameter sets. Controlling of the drive is naturally one of the features in DriveWindow Light. With this software tool, you can monitor up to four signals simultaneously. This can be done in both graphical and numerical format. Any signal can be set to stop the monitoring from a predefined level.

### Sequence programming tool

DriveWindow Light allows the user to visually build and manipulate sequence programming parameters that are loaded into the ACS355. The programming is done in a graphical editor which displays each sequence step and its transitions as an individual block.

Sequence programming enables application specific programming with up to 8 configurable sequences. This new and easy way to preset sequences reduces the need for an external programmable logic control (PLC). In simple applications an external PLC can be left out.

### Startup wizards

Startup wizards make the setting of parameters easy. Simply launch the wizard, select an appropriate assistant eg, for setting analog outputs, and all parameters related to this function are shown together with help pictures.

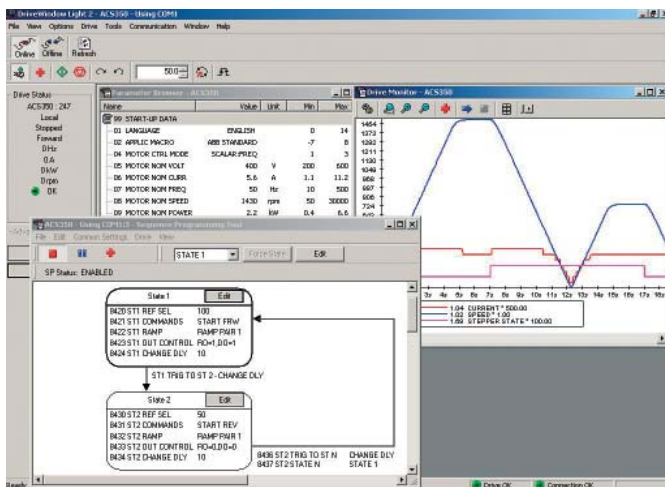

### Highlights

- Graphical sequence programming tool for ACS355
- Editing, saving and downloading parameters
- Graphical and numerical signal monitoring
- Drive control
- Startup wizards

### DriveWindow Light requirements

- Windows NT/2000/XP/Vista/7
- Free serial port from a PC
- Free control panel connector

### Sequence programming example: radio button

In this example, analog input AI1 will start the motor at a fixed speed. This function is useful when the drive is operated using only a potentiometer. The motor speed is proportional to the analog input when analog input level is higher than the fixed level. In this case separate start and stop commands are not needed.

The analog input level is monitored using the ACS355's supervision function. Supervision function status is set as a transition rule between the two states of the sequence program.

In state 1 the drive is in stand-by, monitoring the AI1 level. In state 2 the drive starts in the forward direction and its reference is from AI1. In state 2, the supervision function monitors the AI1 level. If the value falls below the set limit, the sequence program makes a transition to state 1 and the drive is stopped.

There are two ramp pairs from which different ramping times can be selected within each state. It is also possible within the sequence program to control the analog output, digital output and relay output independently.

Supervision function, AI1 scaling to speed reference, and ramp times, can be set independent of the sequence program.

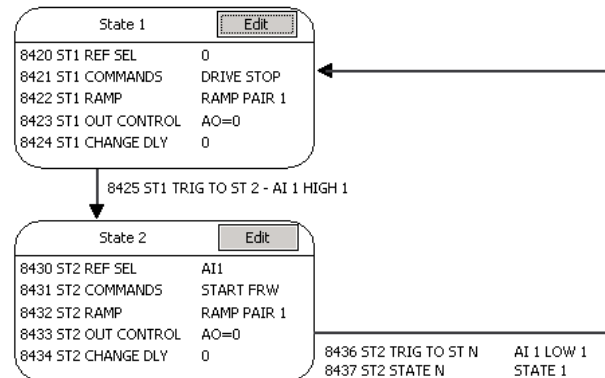



# Options External

A separate order line and type designation is required for any of these external options.

## DriveBrowser

DriveBrowser is an Ethernet network based drive monitoring and tuning PC tool that supports low voltage machinery, standard, and industrial drives throughout their life cycle. It helps users monitor, maintain and set drive parameters on drives connected to an Ethernet network.

## Shares the PLC network

Drives using an Ethernet adapter (RETA-01, RETA-02, or FENA-01) can share the same network where PLC's using Modbus/TCP or EtherNet/IP protocols are connected. This allows users to take advantage of installed networks and reduces additional cabling and infrastructure communication costs.

## Drive startup and maintenance

DriveBrowser includes a parameter browser allowing users to view and set individual parameter values. Parameter sets that have been saved can be used to commission new drives. Additionally, users can compare parameter sets to quickly identify changes over time or changes in configurations. Drive signals are also displayed in the parameter browser.

## Monitor throughout the drives life cycle

The monitor functionality enables users to graphically view signals and parameters while the drive is running. Users select the parameters and signals and set the graph's minimum and maximum values. The resulting display shows each selected value on a graph while the drive is operating. This data can be used to tune the drive for improved performance. The collected data can be saved to a file.

## Quickly assess drive status

The drive status window displays the drives current status, showing the drives control mode, operation status, output frequency, current, power, speed, and the drive state.

## Identify drives easily

Once the installed drives are connected to the network using a fieldbus adapter, users may assign meaningful names to each connected drive and identify drives by type.

## PC based drive control

DriveBrowser provides a built-in drive control panel allowing users to reset faults, start, stop, set the direction, and speed reference values of the connected drive. This functionality may be disabled if the controlling PLC does not allow it for networks that are controlled by a PLC.

## Highlights

- View and set parameters
- Monitor signals graphically and numerically
- Upload/ download drive parameters
- Uses Ethernet network
- Give easily recognizable names to drives
- Control the drive from the PC
- Used throughout the drive's life cycle

## Supported operating systems

- Windows XP/2000/Vista (32bit)/WIN 7 (32bit)

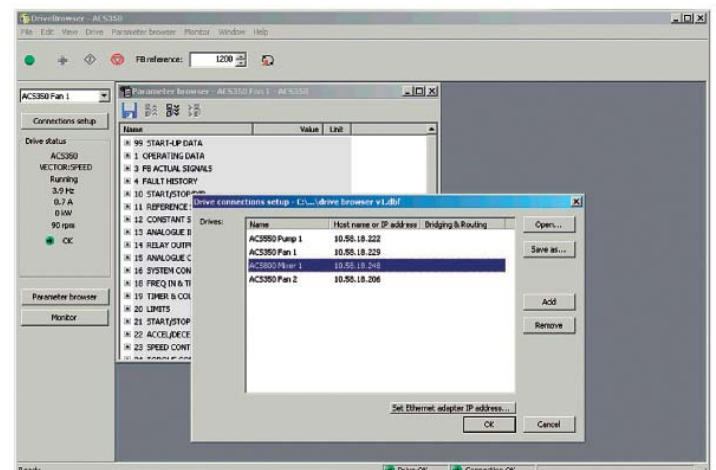

# Options External

A separate order line and type designation is required for any of these external options.

## FlashDrop tool

FlashDrop is a powerful palm sized tool for fast and easy parameter selecting and setting. It gives the possibility to hide selected parameters to protect the machine. Only the parameters needed in the application are shown. The tool can copy parameters between two drives or between a PC and a drive. All the above can be done without a power connection to the drive – in fact, it is not even necessary to unpack the drive.

## DrivePM

DrivePM (drive parameter manager) is a tool to create, edit and copy parameter sets for the FlashDrop tool. For each parameter/group the user has a possibility to hide it, which means that the drive user does not see the parameter/group at all.

## DrivePM requirements

- Windows 2000/XP/Vista/7
- Free serial port from a PC

## FlashDrop package includes

- FlashDrop tool
- DrivePM software on a CD-rom
- User's manual in English and in pdf-format on the CD-rom
- Cable OPCA-02 for connection between the PC and FlashDrop tool
- Battery charger



## Brake resistors

ACS355 is delivered with an integrated brake chopper as standard. Therefore no additional space or installation time is needed. The brake resistor can be selected from the Powerohm resistors table in the price list.

## Input chokes

Input choke smooths the wave shape of mains current and reduces total harmonic distortion (THD). Together with the input choke, the ACS355 is designed to fulfill the requirements of the harmonics standard EN/IEC 61000-3-12. In addition, the input choke provides improved protection against mains voltage transients.

Type designation ACS355-	Frame size	Input choke	$I_{IN}$ without choke [A]	$I_{IN}$ with choke [A]	$I_{TH}$ [A]	$L$ [mH]
<b>1-phase AC supply, 200 to 240 V</b>						
01X-02A4-2	R0	CHK-A1	6.1	4.5	5	8.0
01X-04A7-2	R1	CHK-B1	11.4	8.1	10	2.8
01X-06A7-2	R1	CHK-C1	16.1	11	16	1.2
01X-07A5-2	R2	CHK-C1	16.8	12	16	1.2
01X-09A8-2	R2	CHK-D1	21	15	25	1.0
<b>3-phase AC supply, 200 to 240 V</b>						
03X-02A4-2	R0	CHK-01	4.3	2.2	4.2	6.4
03X-03A5-2	R0	CHK-02	6.1	3.6	7.6	4.6
03X-04A7-2	R1	CHK-03	7.6	4.8	13	2.7
03X-06A7-2	R1	CHK-03	11.8	7.2	13	2.7
03X-07A5-2	R1	CHK-04	12	8.2	22	1.5
03X-09A8-2	R2	CHK-04	14.3	11	22	1.5
03X-17A6-2	R2	CHK-04	24.8	18	22	1.5
03X-24A4-2	R3	CHK-06	41	27	47	0.7
03X-31A0-2	R4	CHK-06	50	34	47	0.7
03X-46A2-2	R4	CHK-06	69	47	47	0.7
<b>3-phase AC supply, 380 to 480 V</b>						
03X-01A2-4	R0	CHK-01	2.2	1.1	4.2	6.4
03X-01A9-4	R0	CHK-01	3.6	1.8	4.2	6.4
03X-02A4-4	R1	CHK-01	4.1	2.3	4.2	6.4
03X-03A3-4	R1	CHK-01	6	3.1	4.2	6.4
03X-04A1-4	R1	CHK-02	6.9	3.5	7.6	4.6
03X-05A6-4	R1	CHK-02	9.6	4.8	7.6	4.6
03X-08A8-4	R1	CHK-03	13.6	7.7	13	2.7
03X-12A5-4	R3	CHK-03	18.8	11.4	13	2.7
03X-15A6-4	R3	CHK-04	22.1	11.8	22	1.5
03X-23A1-4	R3	CHK-04	30.9	17.5	22	1.5
03X-31A0-4	R4	CHK-05	52	24.5	33	1.1
03X-38A0-4	R4	CHK-06	61	31.7	47	0.7
03X-44A0-4	R4	CHK-06	67	37.8	47	0.7

$I_{IN}$  = Nominal input current. When used in 480V network  $I_{IN}$  is 20% lower with rated power.

$I_{TH}$  = Nominal choke thermal current

$L$  = Choke inductance

# Options External

A separate order line and type designation is required for any of these external options.

## EMC filters

The ACS355's internal EMC filter is designed to meet category C3 requirements of EN/IEC 61800-3 standard. External EMC filters are used to enhance the drives electromagnetic performance in conjunction with its internal filtering. Maximum motor cable length depends on required electromagnetic performance, according to the table below.

Type designation ACS355-	Frame size	Filter type	Cable length <sup>1)</sup> with external EMC filter			Cable length <sup>1)</sup> without external EMC filter	
			C1 [m]	C2 [m]	C3 [m]	C3 [m]	C4 [m]
<b>1-phase AC supply, 200 to 240 V</b>							
01X-02A4-2	R0	RFI-11	10	30	-	30	30
01X-04A7-2	R1	RFI-12	10	30	50	30	50
01X-06A7-2	R1	RFI-12	10	30	50	30	50
01X-07A5-2	R2	RFI-13	10	30	50	30	50
01X-09A8-2	R2	RFI-13	10	30	50	30	50
<b>3-phase AC supply, 200 to 240 V</b>							
03X-02A4-2	R0	RFI-32	10	30	-	30	30
03X-03A5-2	R0	RFI-32	10	30	-	30	30
03X-04A7-2	R1	RFI-32	10	30	50	30	50
03X-06A7-2	R1	RFI-32	10	30	50	30	50
03X-07A5-2	R1	RFI-32	10	30	50	30	50
03X-09A8-2	R2	RFI-32	10	30	50	30	50
03X-17A6-2	R2	RFI-33	10	30	50	30	50
03X-24A4-2	R3	RFI-34	10	30	50	30	50
03X-31A0-2	R4	RFI-34	10	30	50	30	50
03X-46A2-2	R4	RFI-34	10	30	50	30	50
<b>3-phase AC supply, 380 to 480 V</b>							
03X-01A2-4	R0	RFI-32	30	30	-	30	30
03X-01A9-4	R0	RFI-32	30	30	-	30	30
03X-02A4-4	R1	RFI-32	50	50	50	30	50
03X-03A3-4	R1	RFI-32	50	50	50	30	50
03X-04A1-4	R1	RFI-32	50	50	50	30	50
03X-05A6-4	R1	RFI-32	50	50	50	30	50
03X-08A8-4	R1	RFI-32	50	50	50	30	50
03X-12A5-4	R3	RFI-33	40	40	40	30	50
03X-15A6-4	R3	RFI-33	40	40	40	30	50
03X-23A1-4	R3	RFI-33	40	40	40	30	50
03X-31A0-4	R4	RFI-34	-	30	-	30	50
03X-38A0-4	R4	RFI-34	-	30	-	30	50
03X-44A0-4	R4	RFI-34	-	30	-	30	50

<sup>1)</sup> Internal EMC filter must be connected with the EMC screw in the drive. When the filter is not connected the C4 maximum cable lengths are allowed to be used.

## EMC standards in general

EN 61800-3 (2004), product standard	EN 55011, product family standard for industrial, scientific and medical (ISM) equipment	EN 61800-3/A11 (2000), product standard
Category C1	Group 1 Class B	1 <sup>st</sup> environment, unrestricted distribution
Category C2	Group 1 Class A	1 <sup>st</sup> environment, restricted distribution
Category C3	Group 2 Class A	2 <sup>nd</sup> environment, unrestricted distribution
Category C4	Not applicable	2 <sup>nd</sup> environment, restricted distribution

# Compact PLC and AC drive starter kit

ACS355 - 01U - 02A4 - 2 + P924

ABB's programmable logic controller (PLC) and AC drive starter kit offer an out-of-box motor control in minutes.

The compact, yet powerful kit, targets small-scale machines and systems requiring PLC control and up to seven drives.

## Easy ordering and fast startup

Providing PLC, AC drive and accessories as a package simplifies ordering and provides quick deliveries. The ordering code for the starter kit is ACS355-01U-02A4-2+P924. Please note that the starter kit is available only in the EMEA region.

A starter kit containing an AC500-eCo PLC and ABB machinery drive, ACS355 (0.37 kW), is intended for evaluation and customization (application programming). The kit contains a ready-made application program based on the AC500 function block library for drives, accessories, user documentation and Control Builder programming environment.

Ready-made reorder packages for ACS355 enables expansion of starter kit to a multiple drives system. AC500 product family offers several controllers for system scaling.

## Benefits of the kit

- Control of a motor in minutes
- Easy ordering of PLC, AC drive and accessories as a kit from ABB's central stock
- Entry-level kit for learning the Control Builder programming environment based on CoDeSys
- Pre-engineered communication libraries for all ABB LV AC drives
- Ready-made HMI visualization
- Cost-efficient system expansion, since the same application program can be used for the entire AC500 PLC platform



# Taking care of your drives, caring about your business

Whether a drive is a part of the product you sell or a component in your production process, reliable and efficient drive operation is key. You will find support from your first meeting with ABB to the drive installation,

commissioning and maintenance, all the way up to the eventual drive replacement and recycling. With offices in over 90 countries, we are well placed to offer you technical advice and local support.

## Installation and commissioning

We offer accurate advice and timely support before and during installation. ABB-certified engineers or third-party channel companies can adjust the drive parameters to meet the precise demands of the application.

## Preventive Maintenance

ABB recommends regular preventive maintenance of drives throughout their lifetime to ensure maximum availability and minimum unplanned repair costs.

Drive preventive maintenance consists of annual drive inspections and component replacements according to product specific maintenance schedules.

## Maintenance intervals

If installed in an appropriate environment, the drive requires very little maintenance. The table lists the routine maintenance intervals recommended by ABB.

Maintenance	Interval
Reforming of capacitors	Every year when stored
Check of dustiness, corrosion and temperature	Every year
Replacement of the cooling fan (frame sizes R1 to R4)	Every three years
Check and tightening of the power terminals	Every six years
Replacement of the battery in the assistant control panel	Every ten years
Testing of Safe torque off (STO) operation and reaction	Every year

Consult your local ABB drives service representative for more details on the maintenance or visit [www.abb.com/drives](http://www.abb.com/drives).



## Fast and reliable global delivery and support

ABB drives, spare parts and services are available worldwide and can be purchased through the dedicated global service and support network. More than 1400 companies, located throughout the world and able to serve you locally as well as provide you technical support. These companies include ABB's own offices and authorized third party channel companies

Check your local ABB contact from [www.abb.com/searchchannels](http://www.abb.com/searchchannels)

## Training services

To enhance personnel's product knowledge, and, with that, improve plant safety and availability we offer a selection of on-line and hands-on courses. Drives courses including hands-on exercises are run at local training centers.

Check for more information about ABB's training centers and the courses from [www.abb.com/abbuniversity](http://www.abb.com/abbuniversity).



# Contact us

For more information please contact your local ABB representative or visit:

**[www.abb.com/drives](http://www.abb.com/drives)**

© Copyright 2014 ABB. All rights reserved.  
Specifications subject to change without notice.

3AUA0000081917 REV E US 15.4.2014 #17035

Power and productivity  
for a better world™

